

# **FIFA Quality Concept for Football Turf**

## **Handbook of Test Methods**

**January 2008 Edition**

## Contents

- 1 Introduction
- 2 Normative references
- 3 Laboratory test specimens
- 4 Field test positions
- 5 Test conditions
- 6 Balls used for testing
- 7 Football studs used for testing
- 8 Determination of Football Rebound
- 9 Determination of Angle Ball Rebound
- 10 Determination of Ball Roll
- 11 Determination of Shock Absorption
- 12 Determination of Standard Vertical
- 13 Determination of Rotational Resistance
- 14 Determination of Linear Friction Stud Slide Value and Stud Deceleration Value
- 15 Determination of Skin / Surface Friction & Skin Abrasion
- 16 Procedure for Simulated Mechanical Abrasion during Use
- 17 Procedure for Artificial Weathering
- 18 International and European Standard test methods adopted by FIFA

Whilst every effort has been made to ensure the accuracy of the information contained in this Handbook any party who makes use of any part of this Handbook in the development of a football turf pitch (a "User") does so at its own risk and shall indemnify FIFA, their officers, directors, servants, consultants and agents against all claims, proceedings, actions, damages, costs, expenses and any other liabilities for loss or damage to any property, or injury or death to any person that may be made against or incurred by FIFA arising out of or in connection with such User's use of this Handbook.

Compliance with the requirements detailed in this Handbook by a User does not of itself confer on that User immunity from legal obligations.

Compliance with the requirements detailed in this Handbook by a User constitutes acceptance of the terms of this disclaimer by that User.

FIFA reserve the right to amend, update or delete sections of this manual at any time as they deem necessary.

## 1 Introduction

This Handbook describes the procedures for assessing artificial turf football surfaces under the FIFA Quality Concept. Although the manual has been written to specify how Football Turf (artificial turf surfaces) should be tested the ball/surface and player/surface tests can also be used to assess the qualities of natural turf fields.

This edition of the manual supersedes previous editions with effect from 30<sup>th</sup> January 2008.

## 2 Normative references

This Handbook incorporates by dated or undated reference provisions from other publications. For dated references, subsequent amendments to or revisions of any of these publications will apply to this Handbook only when incorporated into it by amendment or revision. For undated references, the latest edition of the publication referred to applies.

## 3 Laboratory test specimens

- 3.1 A Football Turf is defined as the synthetic surface and infill, any shockpad and all supporting layers that influence the sports performance or biomechanical response of the surface.
- 3.2 Tests shall be made on all elements of the construction that influence the sports performance or biomechanical response of the surface.
- 3.3 Unless a Football Turf is laid on a base that is designed to contribute to the dynamic performance of the surface laboratory tests shall be carried out on tests specimens laid on a rigid flat floor.
- 3.4 If a Football Turf is laid on an a base that is designed to contribute to the dynamic performance of the surface the measurements of ball rebound, angle ball rebound, shock absorption and vertical deformation shall be made on a test specimen comprising the Football Turf and the base, laid to the depth specified by the manufacturer or supplier.
- 3.5 Laboratory tests for ball roll, rotational resistance, stud slide & deceleration, skin / surface friction and skin abrasion shall be made on all elements that influence the response - this does not normally include the supporting layers.
- 3.6 Size of test specimen

Test specimens shall be equal to or greater than the sizes stated in Table 1.

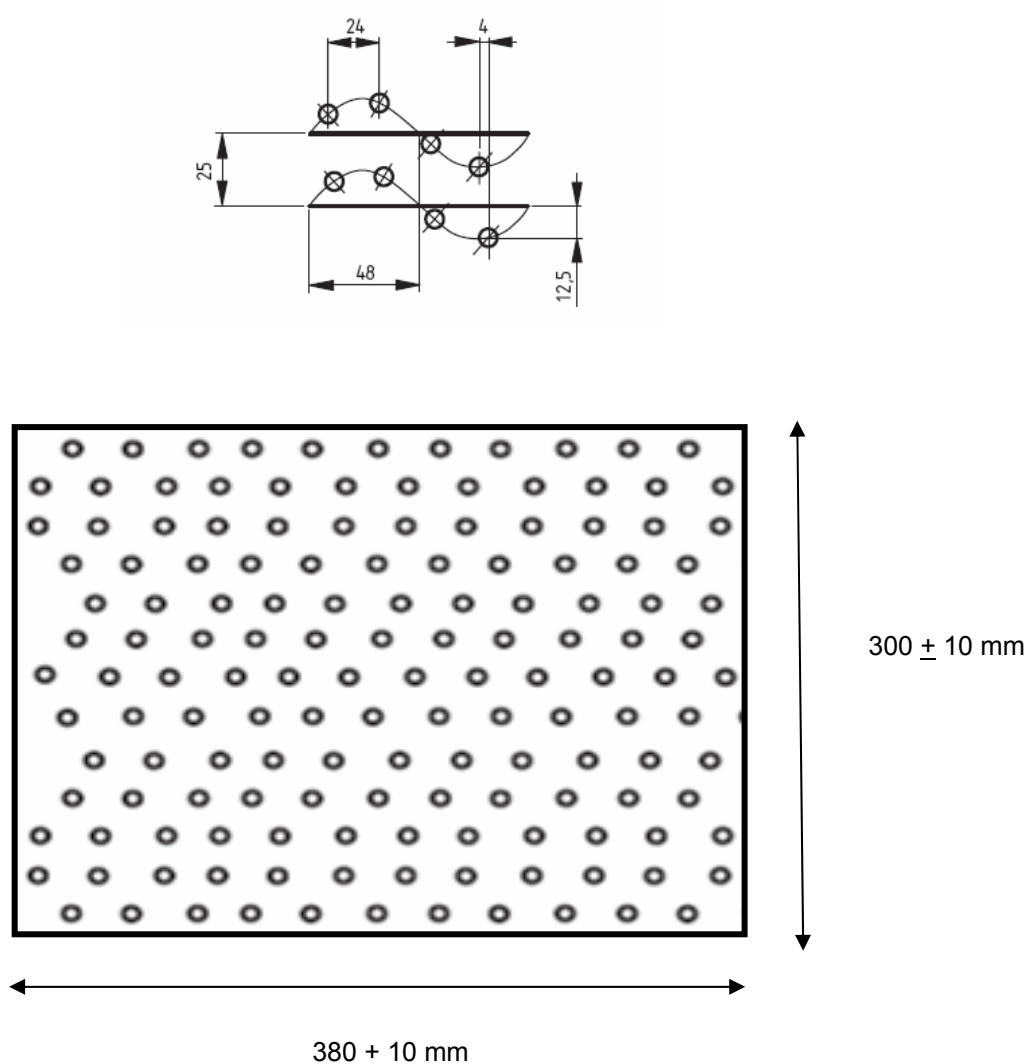
<b>Test</b>	<b>Minimum length of test specimen</b>	<b>Minimum width of test specimen</b>
Ball rebound	1.0m	1.0m
Angle ball rebound	1.0m	1.0m
Ball roll	11.0m	1.0m
Shock absorption	1.0m	1.0m
Vertical deformation	1.0m	1.0m
Rotational resistance	1.0m	1.0m
Stud Slide Value & Stud Deceleration Value	0.5m	0.5m
Surface Friction / Abrasion	1.0m	1.0m
Sub-ambient & Elevated tests	0.4m	0.4m
Simulated wear	0.8m	0.4m
Artificial weathering: carpet pile yarn(s)	5m length	

3.7 Unless specified in the test method laboratory test specimens shall not include joints or inlaid lines.

3.8 Preparation of test specimens

Test specimens shall be prepared strictly in accordance with the manufacturer's instructions. If required this may include consolidation of the infill by means of a conditioning roller (see below) or other means. The same conditioning procedure shall be used on all test specimens being prepared for sports performance and simulated use tests.

All test specimens (other than those being prepared for simulated use, tests at sub-ambient and elevated temperatures and artificial weathering) shall then be conditioned prior to test by passing a hand-pulled roller over the test specimen for a minimum of 50 cycles and a maximum of 250 cycles (one cycle comprises one outward and one return path by a single roller, where double rollers, etc are used the number of cycles shall be adjusted pro-rota). The barrels of the roller shall weigh  $30 \pm 0.5$  kg, be  $118 \pm 5$  mm in diameter and have plastic studs (see Section 7) mounted as shown in Figure 1.



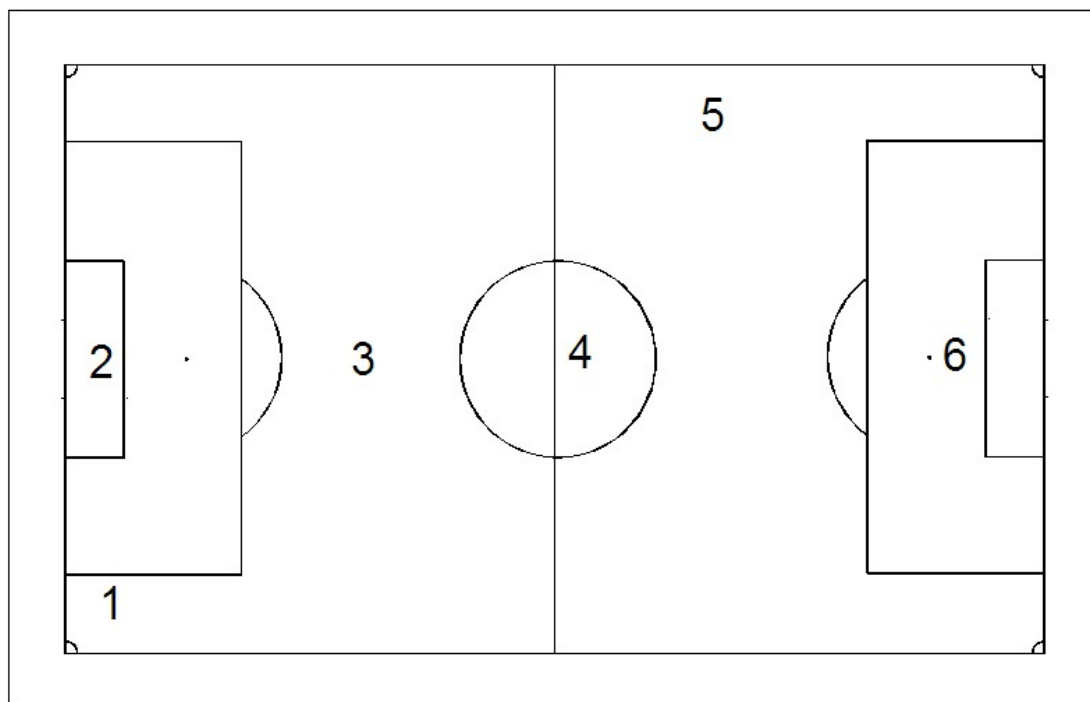
**Figure 1 – stud pattern on conditioning roller and Lisport Wear Machine**

#### 4 Field test positions

Tests on site shall be made in the positions shown on Figure 2.

All field tests shall be undertaken in positions 1 – 6. The orientation of test positions shall be determined by the test institute.

Angle ball rebound tests shall be undertaken in the directions specified in clause 9.6.2.



**Figure 2 - field test positions**

Field tests should not be made on joints or inlaid lines, other than boll roll that will cross them.

#### 5 Test conditions

##### 5.1 Laboratory tests

Laboratory tests shall be made at an ambient laboratory temperature of  $23 \pm 2^\circ \text{C}$ .

Test specimens shall be conditioned for a minimum of 3 hours at the laboratory temperature prior to test.

Laboratory tests shall be made on dry and wet test specimens as specified in the appropriate test procedure.

##### 5.2 Preparation of wet test specimens

Wet specimens shall be prepared by evenly applying to the test piece a volume of water that thoroughly soaks the specimen (if in doubt this should be equal to the volume of the

test specimen). Following wetting the test specimen shall be allowed to drain for 15 minutes and the test carried out immediately thereafter.

### 5.3 Field (site) tests

Tests on site shall be made under the prevailing meteorological conditions, but with the surface temperature in the range of +5°C to +40°C. If weather conditions make it impossible to undertake tests within the specified temperature range the deviation from the specified test conditions shall be clearly noted in the test report. In cases of failure a retest shall be undertaken within the specified range.

The surface and ambient temperatures and the ambient relative humidity at the time of test shall be reported.

Ball roll and ball rebound tests (unless the test area is screened from the wind) shall be made when the maximum prevailing wind speed is less than 2 m/s. The wind speed at the time of test shall be reported.

If weather conditions make it impossible to undertake ball roll tests within the specified wind speed range and the ball roll is found to exceed the relevant requirement a reduced test programme may be carried out where screening (e.g. by means of a plastic tunnel) is used to reduce the maximum wind speed to less than 2 m/s providing the free pile height (height of pile above any infill) is consistent ( $\pm 3$ mm of the mean for the pitch) and the pile over the entire field is predominately vertical in each of the standard Field Test Positions. In the reduced test programme ball roll shall be measured in three directions (0°, 90° and 180°) on at least one area of the pitch. If the free pile height is found to be inconsistent ( $> \pm 3$ mm of the mean for the pitch) or not predominately vertical in each test position ball roll shall be measured in each of the standard Field Test Positions using screening as necessary. The Mean Free Pile Height for the pitch shall be calculated by measuring the free pile height at each of the field test positions at 0m, 5m and 8m spacings at 0°, 90°, 180° and 270° (nine readings at each of the six test positions).

## 6 **Balls used for test**

Tests shall be made with a FIFA approved football. Prior to any test, the pressure of the ball shall be adjusted within the manufacturer's specified range so the ball gives a rebound on concrete to the bottom of the ball, at the temperature the test will be made, of  $1.35 \pm 0.03$ m, from a drop height of  $2.0 \pm 0.01$ m.

To prevent damage to the skin of the ball the ball used to measure ball roll shall not be used for any other tests.

Note: To minimise the affect on results of the inherent variations found in footballs, FIFA accredited test laboratories are supplied with specially selected test balls.

## 7 **Football studs used for test**

The studs used on the Rotational Resistance, Linear Friction Stud Slide Value and Friction Linear Stud Deceleration Value, Lisport Wear Machine and sample conditioning roller shall be in accordance with Figure 3. They shall be manufactured from plastic and have a Shore A Hardness of  $96 \pm 2$ .

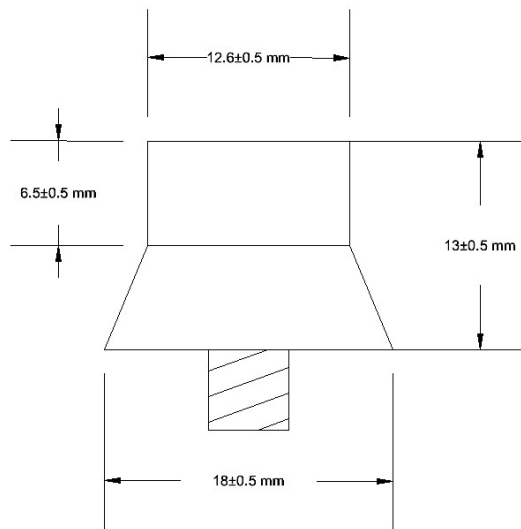


Figure 3 - profile of football stud (new)

#### **Stud replacement – simulated wear**

After every twenty tests the length of 15 studs removed at random from the rollers shall be determined and the mean length and the standard deviation of the fifteen studs.

If the mean length is less than 11.0mm, the standard deviation is more than 0.5 or any one stud has a length of less than 10mm all the studs on both rollers shall be replaced.

#### **Stud replacement – Rotational Resistance**

After a maximum of fifty tests the length of the studs shall be determined. If any stud is found to be less than 11.0mm all shall be replaced.



## **8 Determination of ball rebound (FIFA Test Method 01)**

### **8.1 Principle**

A ball is released from 2m and the height of its rebound from the surface calculated.

Laboratory tests are also undertaken to assess the affects on this property of compaction through simulated use of the surface.

### **8.2 Test apparatus**

#### **8.2.1 Measuring device**

The test apparatus comprises:

- An electro magnetic or vacuum release mechanism that allows the ball to fall vertically from 2.00 ±0.01m (measured from the bottom of ball) without imparting any impulse or spin.
- Vertical scale to allow the drop height of the ball to be established.
- Timing device, activated acoustically, capable of measuring to an accuracy of 1ms.
- Football.
- Means of measuring wind speed to an accuracy of 0.1 m/s (field tests only).

### **8.3. Test procedure**

Validate the vertical rebound of the ball on concrete immediately before testing.

Release the ball from 2.00 ±0.01m, bottom of ball to top above the top of the infill (in filled systems) or on the top of the pile on unfilled systems of playing surface, and record the time between the first and second impact in seconds.

### **8.4 Calculation and expression of results**

For each test calculate the rebound height using the formula:

$$H = 1.23 (T - \Delta t)^2 \times 100$$

Where:

H = rebound height in cm

T = the time between the first and second impact in seconds

$\Delta t = 0.025s$

Report the value of ball rebound to the nearest 0.01m as an absolute value in metres e.g. 0.80m.

Quote the uncertainty of measurement as ± 0.03m.

## **8.5 Laboratory tests at 23 ±2°C**

### **8.5.1 Procedure**

Determine the ball rebound of the test specimen in five positions, each at least 100mm apart and at least 100mm from the sides of the test specimen. Remove any displaced infill from adjacent tests positions prior to making a test.

Undertake tests under dry and wet conditions, as appropriate.

### **8.5.2 Calculation of results**

Calculate the mean value of ball rebound from the five tests.

## **8.6 Laboratory tests after simulated mechanical abrasion during use**

### **8.6.1 Procedure**

Condition the test specimen in accordance with Section 16.

Carefully remove the test specimen from the Lisport Wear Machine and place on the test floor.

Determine the ball rebound of the test specimen in three positions each at least 100mm from the sides of the test specimen. Remove any displaced infill from adjacent tests positions prior to making a test

Undertake tests under dry conditions only.

### **8.6.2 Calculation of results**

Calculate the mean value of ball rebound from the three tests.

## **8.7 Field tests**

### **8.7.1 Test Conditions**

Tests shall be made under the meteorological conditions found at the time of test subject to the limits of Section 5.3. The conditions shall be reported.

### **8.7.2 Procedure**

Record the maximum wind speed during the test.

At each test location make five individual measurements, each at least 300mm apart.

### **8.7.3 Calculation of results**

Calculate the mean value of ball rebound from the five tests for each test location.

## **9 Determination of Angle Ball Rebound (FIFA Test Method 02)**

### **9.1 Principle**

A ball is projected, without spin, at a specified speed and angle, onto the surface and the angle ball rebound calculated from the ratio of the ball's velocity just after impact to the velocity just prior to impact.

### **9.2 Test apparatus**

The test apparatus comprises:

- A pneumatic cannon capable of projecting the ball onto the surface at the specified angle and velocity.
- Radar gun capable of determining the horizontal speed of the ball before and after its impact with the test specimen to an accuracy of  $\pm 0.1$  km/h.
- Football.

### **9.3 Test procedure**

Validate the vertical rebound of the ball on concrete immediately before the testing.

Adjust the pneumatic cannon so that the vertical height of the inner diameter of the cannon mouth is  $0.90 \pm 0.02$ m above the top of the infill (in filled systems) or on the top of the pile on unfilled systems and so the ball departs the cannon at an angle of  $15 \pm 2^\circ$  to the horizontal and has a velocity of  $50 \pm 5$  km/h just prior to impacting the surface.

Position the radar so it is adjacent to the cannon, parallel to the surface, aligned in the direction the ball will be fired and at a vertical height of between 450mm and 500mm from the test surface.

Project the ball onto the surface and record the velocity of the ball immediately before and immediately after impact with the surface.

Repeat the procedure five times, ensuring that ball does not strike the same position twice.

### **9.4 Calculation and expression of results**

Calculate the angle ball rebound using the formula:

$$\text{Angle ball rebound (\%)} = (S2 / S1) \cdot 100$$

Where:

S2 = velocity after rebound in km/h

S1 = velocity before rebound in km/h

Report the angle ball rebound as a percentage to the nearest whole number e.g. 55%.

Quote the uncertainty of measurement as  $\pm 5\%$  absolute.

## **9.5 Laboratory tests**

### **9.5.1 Procedure**

Determine the angle ball rebound of the test specimen, ensuring each test position is each at least 300mm apart and at least 100mm from the sides of the test specimen.

Undertake tests under dry and wet conditions, as appropriate.

If the test results are influenced by factors such as turf pile pattern etc, carry out the tests in such a way that a set of readings is obtained in directions giving maximum and minimum values.

### **9.5.2 Calculation of results**

Calculate the mean value of angle ball rebound from the five tests for each direction of test.

Calculate the mean value of angle ball rebound from the different directions of test.

## **9.6 Field tests**

### **9.6.1 Test Conditions**

Tests shall be made under the meteorological conditions found at the time of test subject to the limits of Section 5.3. The conditions shall be reported.

### **9.6.2 Test Locations**

The directions of tests shall be:

Position 1 across the penalty box

Position 2 away from the adjacent goal

Position 3 across the field opposite to direction position 1

Position 4 diagonally towards position 1

Position 5 diagonally towards position 6

Position 6 towards adjacent goal

At each test location make five individual measurements in a single direction, each at least 300mm apart.

### **9.6.3 Calculation of results**

Calculate the mean value of angle ball rebound from the five tests for each test location.

## 10 Determination of Ball Roll (FIFA Test Method 03)

### 10.1 Principle

A ball is rolled down a ramp and allowed to roll across the surface until it comes to rest. The distance the ball has travelled across the surface is recorded.

### 10.2 Test apparatus

The test apparatus comprises:

- A ball roll ramp as shown in Figure 4 consisting of two smooth parallel rounded bars, whose inside edges are  $100 \pm 10$  mm apart. The ball shall transfer from the ramp to the surface without jumping or bouncing.
- Method of measuring the distance the ball rolls to an accuracy of  $\pm 0.01$  m (e.g. steel tape, laser).
- Football
- Means of measuring wind speed to an accuracy of 0.1 m/s (field tests only).

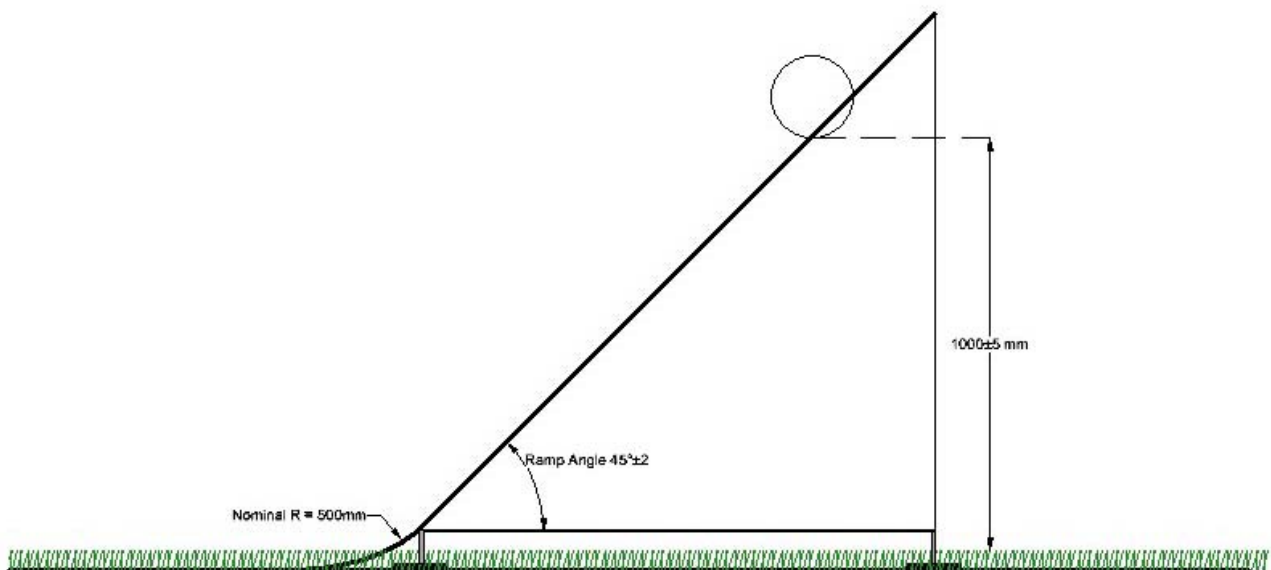


Figure 4 Ball Roll ramp

### 10.3 Test procedure

Validate the vertical rebound of the test ball on concrete immediately before the testing.

Adjust the ramp so that it is perpendicular to the surface and so the end of the guide rails are sitting on the top of the infill (in filled systems) or on the top of the pile on unfilled systems so that the ball rolls smoothly from the ramp onto the surface with out jumping or bouncing.

Place the ball on the ball roll ramp so the point below the centre of the ball sitting on the ramp is  $1000 \pm 5$  mm above the test specimen.

Release the ball and allow it to roll down the ramp and across the test specimen until it comes to rest.

Measure the distance from the point the ball first comes into contact with the test specimen (top of carpet pile) to the point below the centre of the ball resting on the test specimen at the position the ball came to rest.

#### **10.4 Expression of results**

Report the Ball Roll value to the nearest 0.1m e.g. 6.9m

Quote the uncertainty of measurement as  $\pm 0.05$ m.

#### **10.5 Laboratory tests**

##### **10.5.1 Procedure**

From one end of the test specimen determine the Ball Roll in five positions, each at least 100mm from the sides of the test specimen.

Repeat the test from the opposite end of the test specimen to assess the influence of factors such as turf pile pattern, etc.

Undertake tests under dry and wet conditions, as appropriate.

##### **10.5.2 Calculation of results**

Calculate the mean value of Ball Roll from the 5 tests in each direction.

Calculate the mean of the two test directions.

#### **10.6 Field tests**

##### **10.6.1 Test conditions**

Tests shall be made under the meteorological conditions found at the time of test subject to the limits of Section 5.3. The conditions shall be reported.

##### **10.6.2 Procedure**

Record the wind speed during the test.

At each test location make five individual measurements, each at least 100mm apart.

Undertake the tests in at least four directions ( $0^\circ$ ,  $90^\circ$ ,  $180^\circ$  and  $270^\circ$ ) to determine if the result is influenced by factors such as slope or turf direction.

##### **10.6.3 Calculation of results**

For each test position/direction calculate the mean value of ball roll from the five tests.

Calculate the mean value of ball roll from all tests at each test position.

## 11 Determination of Shock Absorption (FIFA Test Method 04)

### 11.1 Principle

A mass is allowed to fall onto a spring that rests, via a load cell and test foot on the test specimen, and the maximum force applied is recorded. The percentage reduction in this force relative to the maximum force measured on a concrete surface is reported as the 'Force Reduction'.

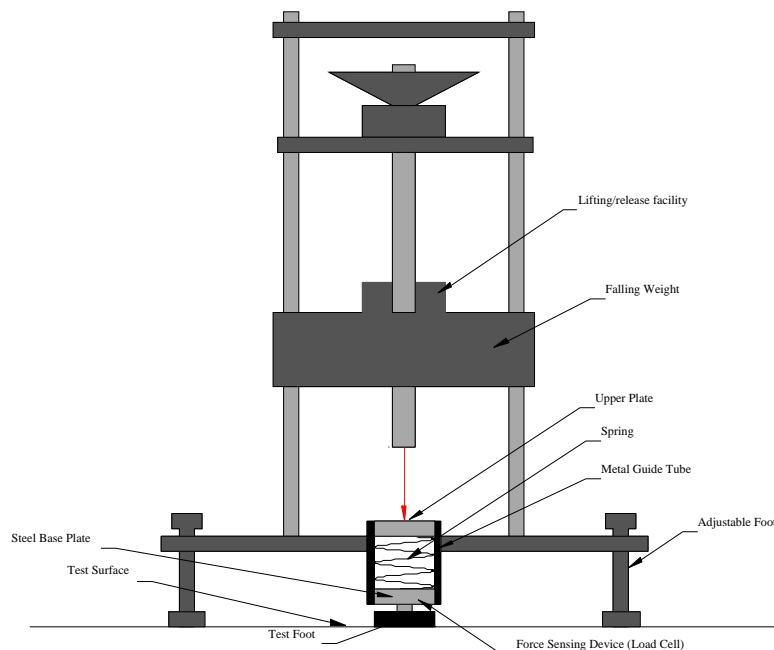
Laboratory tests are also undertaken to assess the effects on this property of compaction through simulated use of the surface

### 11.2 Test apparatus

#### 11.2.1 Artificial Athlete

The principle of the apparatus is shown in Figures 5. It consists of the following principal components:

- Falling weight,  $20 \pm 0.1$  kg with a hard striking surface, which is guided so as to fall smoothly and vertically with minimum friction.
- Spiral spring, whose characteristic, when mounted in the assembly described below, is linear with a spring rate of  $2000 \pm 60$  N/mm over the range 0.1 kN to 7.5 kN. The spring shall be fitted with a hard upper plate and have an outer diameter of between 68.0mm and 70.0 mm. The spring shall be manufactured by milling from solid and have three or more coaxial coils, which must be rigidly fixed together at their ends.
- Test frame with equally three spaced adjustable supporting feet, no less than 250 mm from the point of application of the load.



**Figure 5 - Artificial Athlete – Shock Absorption**

- Metal guide tube with an interior diameter  $72.0 \pm 1$  mm.
- Electrical force sensing load cell, with a capacity of 10 kN. The load cell, spring and upper plate shall be attached to the upper side of the steel base plate.
- A means of supporting the weight, allowing it to be set to the fall height with an uncertainty of no greater than  $\pm 0.5$  mm.
- A means of conditioning and recording the signal from the load cell and a means of displaying this signal. The channel frequency class of the conditioning amplifier, as described in ISO 6487, shall be  $\geq 1$  kHz.
- A means of ensuring anti-aliasing does not occur. This shall be achieved by applying an analogue pre-filter with a cut-off frequency of approximately 500 Hz, to prepare the signal for final filtering. The conditioning amplifier shall be followed by or shall incorporate a low-pass filter having a 2nd order Butterworth characteristic with a -3 dB frequency of 120 Hz. Filtration shall be implemented in hardware or software. The response of the system at any given frequency shall be within  $\pm 0.5$  dB of the expected response, calculated on the basis of the Butterworth function. Where digital recording means are employed, the word length shall be  $\geq 12$  bits, the amplitude of the signal shall be no less than 25 % of the equipment full scale and the sampling frequency shall be  $\geq 2$  kHz or twice the upper frequency response limit of the amplifier/filter system preceding the digital system, whichever is greater.
- Test Foot consisting of a round steel plate (diameter  $70 \pm 0.1$  mm) and minimum thickness 10 mm, having a rounded base with a nominal radius of 500 mm and edge radii or chamfer (maximum 1 mm). The load cell, spring and upper plate shall be attached to the upper side of the steel plate. The total weight of the testing foot (without guide tube) shall be  $3.0 \pm 0.3$  kg.
- Reference concrete comprising a rigid, non-vibrating, smooth, level and even concrete floor on which a peak force ( $F_{max}$ ) of  $6.60 \pm 0.25$  kN is achieved.

#### 11.2.2 Apparatus for tests at -5°C

- Conditioning cabinet capable of maintaining a temperature of -8°C to -12°C.
- Sample tray with internal dimensions of at least 510 mm by 510 mm. The depth of the tray shall be at least 10 mm greater than the test specimen and the base of the tray shall be of rigid mesh, to allow the free draining of water from the test specimens.
- Temperature probe.

#### 11.2.3 Apparatus for tests at 40°C

- Air circulating oven conforming to ISO 188
- Temperature probe.



### 11.3 Procedure

#### 11.3.1 Measurement of reference force $F_{\max(\text{concrete})}$

Set the apparatus on the concrete floor so that it is vertical.

Set the height of the lower face of the impact weight so that it is  $55 \pm 0.5$  mm above the force measurement assembly.

Allow the weight to fall onto the force measurement assembly. Record the peak force applied to the surface during the impact.

Repeat the procedure ten times, giving a total of 11 impacts. Record the average value of peak force from the second to the eleventh impact and denote it as  $F_{\max(\text{concrete})}$ .

Carry out this procedure at intervals of at least three months or whenever components of the test apparatus change.

#### 11.3.2 Measurement of Force Reduction (test piece)

Set up the apparatus so that it is vertically positioned on the test specimen.

Set the height of the lower face of the impact so that it is  $55 \pm 0.5$  mm above the force measurement assembly.

Allow the weight to fall onto the force measurement assembly.

Record the peak force applied to the surface in the course of the impact.

#### 11.3.3 Calculation and expression of results

Calculate the Force Reduction from the expression.

$$FR = \left( 1 - \frac{F_{\max(\text{testpiece})}}{F_{\max(\text{concrete})}} \right) \cdot 100 \%$$

where:

FR is the Force Reduction, as a percentage (%).

$F_{\max(\text{test piece})}$  is the measured maximum peak force of the test piece, in Newton (N).

$F_{\max(\text{concrete})}$  is the measured maximum peak force of the concrete, in Newton (N).

Report the mean results to the nearest whole percentage, e.g. 65%.

Quote the uncertainty of measurement as  $\pm 2$  %.

## **11.4 Laboratory tests at $23 \pm 2^{\circ}\text{C}$**

### **11.4.1.1 Procedure**

Determine the Force Reduction of the test specimen, making three repeat measurements at intervals of  $60 \pm 5\text{s}$  on the same spot. Do not brush or adjust the surface in any way between impacts. Check the drop height before each measurement.

Repeat the procedure in three positions, each at least 100mm apart and at least 100mm from the sides of the test specimen.

Undertake tests under dry and wet conditions, as appropriate.

### **11.4.1.2 Calculation of results**

Calculate the mean value of Force Reduction of the second and third impacts for each test position.

Calculate the mean value of the second and third impacts of Force Reduction of the three test positions.

## **11.5 Laboratory tests at $-5^{\circ}\text{C}$**

### **11.5.1 Procedure**

Place the tests specimen in the sample tray and immerse in water to a depth of at least 10 mm above the top of the artificial turf pile. After a minimum of one hour, remove the tests specimen from the water and place it on a free draining base to allow it to drain by gravity for  $30 \pm 2$  minutes before placing the test specimen and sample tray in a conditioning cabinet at a temperature of  $-8^{\circ}\text{C}$  to  $-12^{\circ}\text{C}$ .

After  $240 \pm 5$  min, remove the tests specimen and metal tray from the conditioning cabinet. Unless the test specimen includes an unbound mineral base, carefully remove it from the metal tray ensuring any fill materials are not disturbed.

Place the test specimen on the test floor and allow it to warm. Monitor its temperature using a temperature probe inserted into the test specimen to approximately half the depth of the artificial grass carpet's pile (to a depth of 30mm on a carpet with a pile height of 60mm). When the temperature gauge reads  $-5^{\circ}\text{C}$ , make a measure of Force Reduction (initial impact). Move the apparatus and repeat to obtain three results ensuring the temperature of the test specimen does not rise above  $-3^{\circ}\text{C}$ . Do not brush or adjust the surface in any way before impacts.

Note: cooling a concrete slab in the freezer and using this as the test floor will extend the length of time available to undertake the tests. The concrete slab must be flat and not move during the tests.

Undertake tests under dry conditions only.

### **11.5.2 Calculation of results**

Calculate the mean value of Force Reduction ( $-5^{\circ}\text{C}$ ) of the three initial impacts.

## 11.6 Laboratory tests at 40°C

### 11.6.1 Procedure

Preheat the oven to a temperature of  $40\text{ °C} \pm 2\text{ °C}$ . Place the tests specimen in the oven ensuring it is stationary, free from strain and freely exposed to air on all sides. After  $240 \pm 5$  min, remove the tests specimen from the oven. Place the tests specimen on the test floor and determine the Force Reduction (flat foot) of the test specimen making three repeat measurements at intervals of  $60 \pm 5$ s on the same spot, ensuring the temperature of the test piece does not fall below  $38\text{ °C}$ . Do not brush or adjust the surface in any way between impacts. Check the drop height before each measurement.

If the result falls outside the specified range for the surface type repeat the procedure three times ensuring the positions are at least 100mm apart and at least 100mm from the sides of the test specimen.

Note: heating a concrete slab in the oven and using this as the test floor will extend the length of time available to undertake the tests. The concrete slab must be flat and not move during the tests.

Undertake tests under dry conditions only.

### 11.6.2 Calculation and expression of results

Calculate the mean value of Force Reduction ( $40\text{ °C}$ ) of the second and third impacts for each test position.

If required calculate the mean value of the second and third impacts of Force Reduction ( $40\text{ °C}$ ) of the three test positions.

## 11.7 Laboratory tests after simulated mechanical abrasion during use

### 11.7.1 Procedure

Condition the test specimen in accordance with Section 16.

Carefully remove the test specimen from the Lisport Wear machine and place on the test floor.

Determine the Force Reduction of the test specimen in three positions.

Undertake tests under dry conditions only.

### 11.7.2 Calculation and expression of results

Calculate the mean value of Force Reduction of the second and third impacts for each test position.

Calculate the mean value of Force Reduction (simulated use) from the three tests.

## **11.8 Field tests**

### **11.8.1 Test conditions**

Tests shall be made under the meteorological conditions found at the time of test subject to the limits of Section 5.3. The conditions shall be reported.

### **11.8.2 Procedure**

Determine the Force Reduction at each test location.

### **11.8.3 Calculation of results**

Calculate the mean values of Force Reduction for each test location.

## 12 Determination of Standard Vertical Deformation (FIFA Test Method 05)

### 12.1 Principle

A mass is allowed to fall onto a spring that rests, via a load cell and test foot, on the test specimen and the maximum and standard deformation of the surface is determined.

Laboratory tests are also undertaken to assess the affects on this property of compaction through simulated use of the surface

### 12.2 Test apparatus

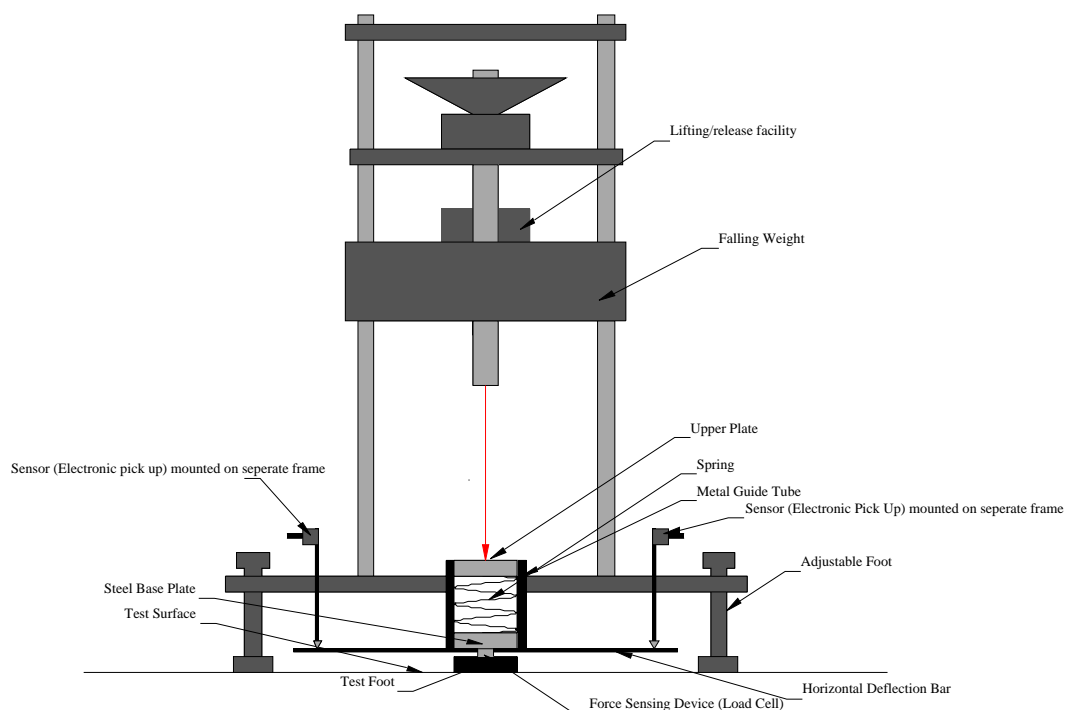
The principle of the apparatus is shown in Figure 6.

It consists of the following components:

- Falling weight of  $20 \pm 0.1$  kg with a hard striking surface guided in such a way as to fall smoothly and vertically with minimum friction.
- Spiral coil spring having diameter of  $69 \pm 1$  mm which, when mounted in the assembly described below, is linear with a spring rate of  $40 \pm 1.5$  N/mm over the 0.1 kN to 1.6 kN.
- Test frame with equally three spaced adjustable supporting feet, no less than 250 mm from the point of application of the load.
- Steel base plate, with a flat lower side; radius of the edge 1 mm, diameter  $70.0 \pm 0.1$  mm; thickness 10 mm min.
- Electrical force sensing load cell, with a capacity of 10 kN. The load cell, spring and upper plate shall be attached to the upper side of the steel base plate.
- Two displacement sensors (e.g. electronic pick-ups) with a measuring range of no less than 20 mm and an accuracy of at least 0.1 mm. The distance between the sensors and centre of the test foot shall be greater than 125 mm and less than 200 mm. The sensors shall be mounted on a separate stand from the falling weight.
- Test Foot consisting of a round steel plate (diameter  $70 \pm 1$  mm) and minimum thickness 10 mm, having an edge radii or chamfer (maximum 1 mm). The force sensing device, spring and upper plate shall be attached to the upper side of the steel plate. Mounted to the test foot shall be two equally spaced horizontal projections for the displacement sensors to register against. The total weight of the testing foot (without guide tube) shall be  $3.5 \pm 0.35$  kg.

Note: The horizontal projections shall be mounted at an adequate height to ensure they do not come into contact with the test specimen during the test.

- Metal guide tube, interior diameter  $72.0 \pm 1$  mm.
- A means of supporting the weight, allowing the drop height to be adjusted and set repeatedly.



**Figure 6 - Artificial Athlete - Vertical Deformation**

- A means of conditioning and recording the signals from the force sensing device and the sensors, and a means of displaying these signals. The channel frequency class of the conditioning amplifier for the force signal, as described in ISO 6487 shall be  $\geq 500\text{Hz}$ . It shall be followed by or shall incorporate a low-pass filter having a 2nd order Butterworth characteristic with a -3 dB frequency of 120 Hz. Filtration may be implemented in hardware or software. The response of the system at any given frequency shall be within  $\pm 0.5$  dB of the expected response, calculated on the basis of the Butterworth function. The signal conditioner for the deformation signal shall have a -1 dB measuring range of min. 100 Hz (-1 dB upper frequency response). The individual signals of the two deformation sensors shall be superposed before calculating the vertical deformation. Where digital recording means are employed, the word length shall be  $\geq 12$  bits, the amplitude of the signal shall be no less than 25 % of the equipment full scale and the sampling frequency shall be  $\geq 0.5$  kHz.

### 12.3 Test procedure

Set the apparatus so that it is positioned vertically on the test specimen.

Adjust the displacement pick-ups so they are equally spaced either side of the falling weight axis. Adjust the deformation pick-ups so they contact the horizontal projections on the test foot. Under this condition the force measurement assembly shall give a surface pre-loading

of  $0.01 \pm 0.005$  N/mm<sup>2</sup> and a corresponding deformation of the surface that equates to the zero position.

Set the height of the lower face of the impact mass so that it is  $120 \pm 0.5$  mm above the spring.

Allow the mass to fall onto the testing foot. Catch the weight as it rebounds to prevent a second impact of the test foot and artificial turf.

Repeat making three measurements at intervals of  $60 \pm 5$  s on the same spot. Do not brush or adjust the surface in any way between impacts. Check the drop height before each measurement.

## 12.4 Calculation and expression of test results

Calculate the Standard Vertical Deformation from the expression.

$$VD = \left( \frac{1500}{F_{\max}} \right) \cdot d_{\max}$$

where:

$d_{\max}$  = the maximum deformation of the test specimen or field

$F_{\max}$  = the maximum force (peak value), in Newton (N)

Report the result to the nearest 0.5mm, e.g. 6.5mm.

Quote the uncertainty of measurement as  $\pm 1$ mm.

## 12.5 Laboratory tests at $23 \pm 2^{\circ}\text{C}$

### 12.5.1 Procedure

Determine the Standard Vertical Deformation in three positions, each at least 100mm apart and at least 100mm from the sides of the test specimen.

Undertake tests under dry and wet conditions, as appropriate.

### 12.5.2 Calculation of results

Calculate the mean value of Standard Vertical Deformation of the second and third impacts for each test position.

Calculate the mean value of the second and third impacts of Standard Vertical Deformation of the three test positions.

## 12.6 Laboratory tests after simulated mechanical abrasion during use

### 12.6.1 Procedure

Condition the test specimen in accordance with Section 16.

Carefully remove the test specimen from the Lisport Wear machine and place on the test floor.

Determine the Standard Vertical Deformation of the test specimen in three positions, each at least 100mm apart and at least 100mm from the sides of the test specimen.

Undertake tests under dry conditions only.

#### 12.6.2 Calculation and expression of results

Calculate the mean value of Standard Vertical Deformation (simulated use) from the three tests.

### **12.7 Field tests**

#### 12.7.1 Test conditions

Tests shall be made under the meteorological conditions found at the time of test subject to the limits of Section 5.3. The conditions shall be reported.

#### 12.7.2 Procedure

At each test location determine the Standard Vertical Deformation.

#### 12.7.3 Calculation of results

Calculate the mean values of Standard Vertical Deformation for each test location.



## 13 Determination of Rotational Resistance (FIFA Test Method 06)

### 13.1 Principle

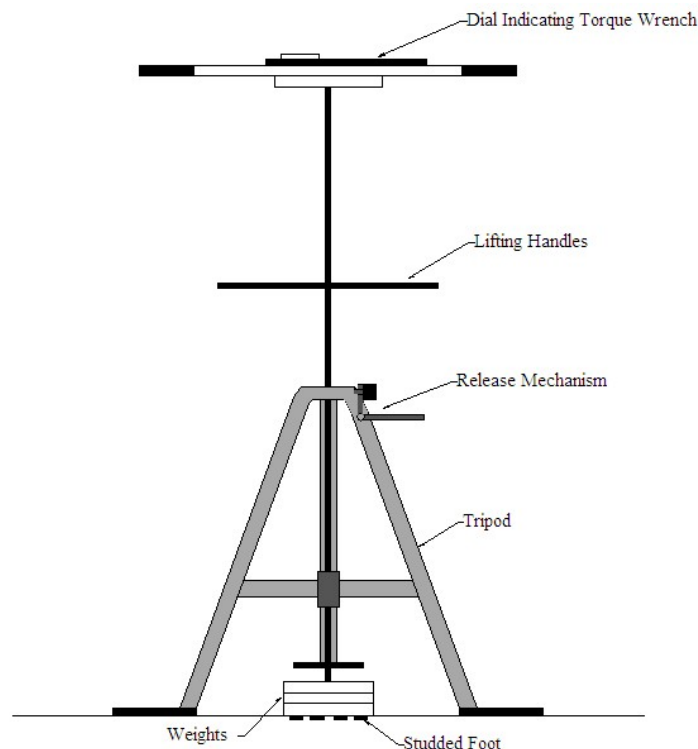
The torque required to rotate a loaded test foot in contact with the surface is measured and the rotational resistance calculated.

Laboratory tests are undertaken to assess the affects on this property of mechanical abrasion of the surface during use.

### 13.2 Test apparatus

The principle of the apparatus is shown in Figure 7. It consists of the following:

- A test foot comprising a metal disc  $145 \pm 10$  mm in diameter with six football studs equally spaced on the bottom surface each  $46 \pm 1$  mm from the centre of the disc.
- A shaft with attached lifting handles that are attached centrally to the centre of the studded disc.
- A two-handed mechanical torque wrench with a scale of 0 to 80Nm in maximum 2 Nm increments, which attaches to the top of the shaft.



**Figure 7 - Rotational Resistance apparatus**

- A set of annular weights which rest centrally on the upper surface of the studded disc and are able to freely rotate. The total mass of the studded disc, weights, shaft and torque wrench, shall be  $46 \pm 2$  Kg.
- Tri-pod and guide to minimise lateral movement of the test foot during tests. The tri-pod shall not restrict the free rotation of the shaft and the guide shall incorporate a means of holding and dropping the weighted test foot onto the test specimen from a height of  $60 \pm 5$ mm.

### **13.3 Test procedure**

Before conducting each test ensure that the disc and studs are cleared of any in-fill/detritus.

Assemble the apparatus and ensure the free movement of the test foot. Remove the torque wrench and drop the weighed test foot from a height of  $60 \pm 5$ mm onto the surface. Reattach the torque wrench.

Zero the torque wrench indicator needle.

Without placing any vertical pressure on the torque wrench and applying minimum rotational torque to the torque wrench, turn the wrench and test foot smoothly, without snatching, at a nominal speed of rotation of 12 rev/min until movement of the test foot occurs and it has rotated through at least  $45^\circ$ .

Record the maximum value displayed on the torque wrench to the nearest Nm.

### **13.4 Calculation & expression of results**

Calculate the mean value of Rotational Resistance.

Report the mean result to the nearest 1Nm, e.g. 40Nm.

Quote the uncertainty of measurement as  $\pm 2$ Nm.

### **13.5 Laboratory tests**

Determine the Rotational Resistance in five positions ensuring each test position is, at least 100mm (outside edge of test foot to outside edge) apart and at least 100mm (outside edge of test foot) from the sides of the test specimen.

Undertake tests under dry and wet conditions, as appropriate.

### **13.6 Laboratory test after simulated use**

Condition the test specimen in accordance with Section 16. Carefully remove the test specimen from the Lisport Wear Machine and place on the test floor. Determine the Rotational Resistance of the test specimen in three positions, each at least 50mm apart (outside edge of test foot to outside edge of test foot) and at least 50mm from the sides of the test specimen. Undertake dry tests only.

## **13.7 Field tests**

### **13.7.1 Test Conditions**

Tests shall be made under the meteorological conditions found at the time of test subject to the limits of Section 5.3. The conditions shall be reported.

### **13.7.2 Procedure**

At each test location make five individual measurements, each at least 100mm (outside edge of test foot to outside edge of test foot) apart.

## 14 Determination of Linear Friction Stud Slide Value & Stud Deceleration Value (FIFA Test Method 07)

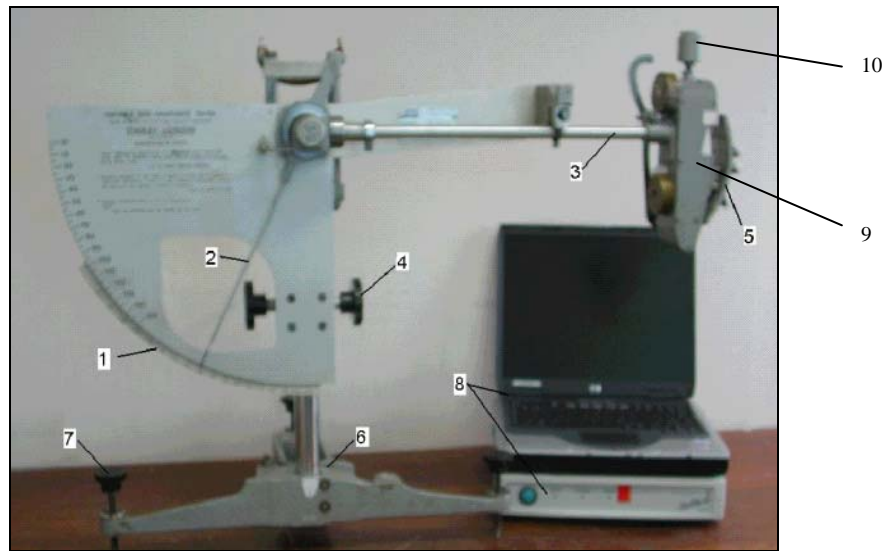
### 14.1 Principle

A test foot with a studded shoe profile attached to a pendulum arm is allowed to strike the surface in a semi-circular motion and the slide of the foot across the surface and the peak deceleration due to the interaction between the studs and the test surface is recorded.

### 14.2 Apparatus

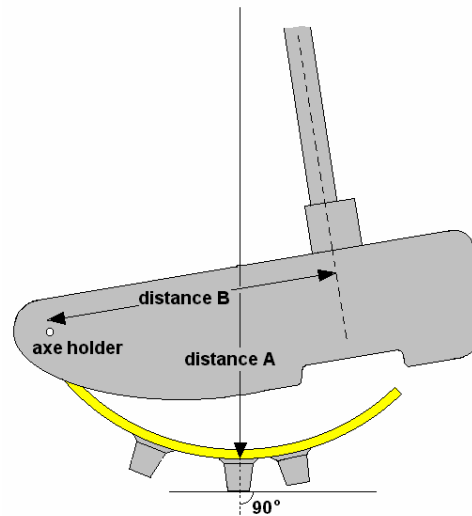
TRRL Skid Resistance Tester (see figure 8) as specified in EN 13036-4 but modified as follows:

- A pendulum arm  $525 \text{ mm} \pm 2 \text{ mm}$  in length (axis to holder for shoe profile, see Figure 9, distance A) fitted with a test foot of length  $114 \pm 2 \text{ mm}$  (see Figure 9, distance B).
- The test foot shall be as detailed in Figure 10. The pressure exerted by the test foot over the first 10mm of compression shall be  $32 \text{ N} \pm 2 \text{ N}$ .
- The mass of the pendulum arm, test foot and studded shoe profile shall be  $2000 \text{ g} \pm 50 \text{ g}$ .
- The distance of the center of gravity of the pendulum arm (including test foot) from centre of oscillation shall be  $410 \pm 10 \text{ mm}$ .
- Modified scale comprising a mirror of the TRRL scale, extended to 250 (i.e. 0 on the TRRL scale is 250 on the modified scale) as shown in Figure 11.
- Acceleration sensor having a range of 0 – 50 g and a recording device capable of measuring the deceleration of the pendulum arm (also in static condition) to an accuracy of  $\pm 1\%$ . The sensor shall be mounted centrally on the balance weight at the rear of the test foot.
- Means of conditioning and recording the signal from the deceleration sensing device and a means of displaying the recorded signal. The channel frequency class of the conditioning amplifier, as described in ISO 6487, shall be 1 kHz or greater. The system shall be able to record the peak value of single deceleration force-pulse signals of 10ms duration with an accuracy of no greater than  $\pm 0.2\%$ . If digital recording techniques are used the word length shall be no less than 16 bits, the amplitude of the signal shall be no less than 25% of the equipment full scale and the sampling frequency shall be no less than 2 kHz or twice the upper frequency response limit of the amplifier system preceding the digital system, whichever is the greater. Butterworth filters shall be 600Hz, 2<sup>nd</sup> order.

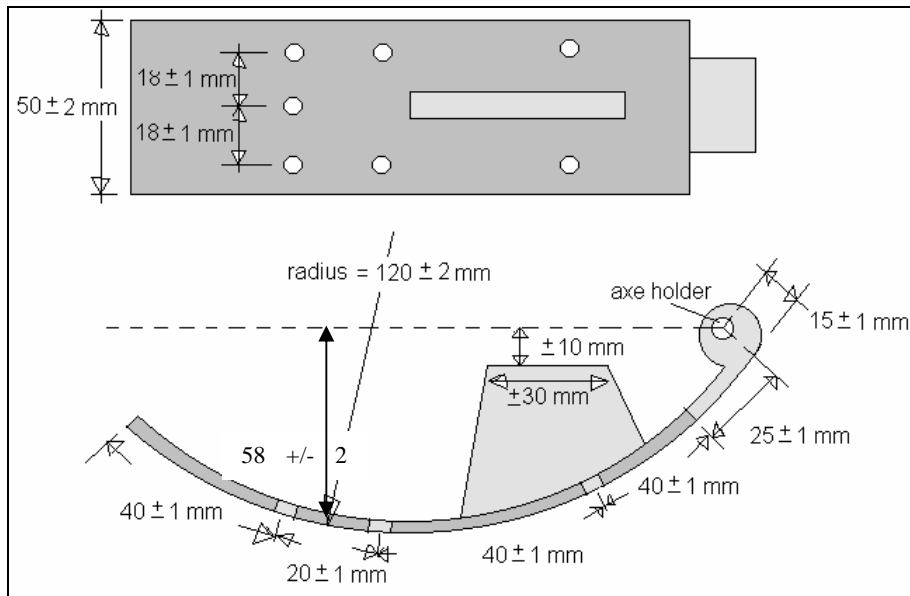


**Figure 8 - Linear Friction Tester**

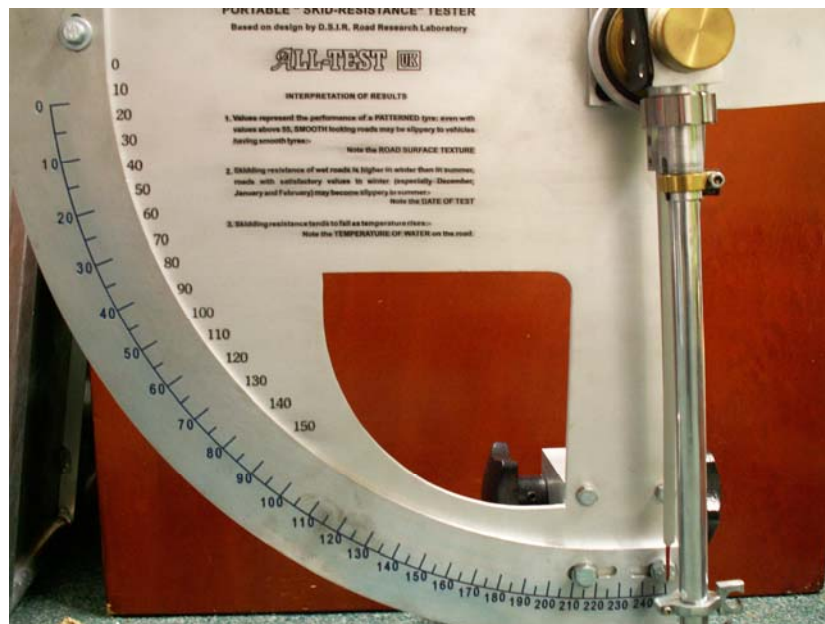
- |   |                         |    |  |
|---|-------------------------|----|--|
| 1 | Modified scale          | 2  | Pointer                                |
| 3 | Pendulum arm            | 4  | Vertical adjustment screw              |
| 5 | Holder for shoe profile | 6  | Bubble level                           |
| 7 | Levelling screws        | 8  | Electronics for recording deceleration |
| 9 | Test foot               | 10 | Accelerometer                          |



**Figure 9 - pendulum and zero-position test foot**



**Figure 10 - dimensions stud mounting plate**



**Figure 11 - scale of Stud Slide value**

## 14.3 Test Procedure

### 14.3.1 Calibration of the apparatus

Place the apparatus on a rigid surface and adjust the levelling screws so the apparatus is horizontal.

Adjust the vertical adjustment screw to raise the axis of the pendulum arm so that the pendulum can swing freely.

Adjust the friction plate in the pointer mechanism so that when the pendulum arm is released from its horizontal position it comes to a stop at the zero position on the scale.

Set the zero position by adjusting the test foot so the studs in the middle are placed horizontally onto the rigid surface (figure 9). Mark this setting Position A (Figure 12). Adjust the accelerometer sensor so it reads zero when the pendulum hangs horizontally.



**Figure 12 - Position A markers**

Place the pointer needle against the pendulum arm and align the pendulum arm with Position A. Adjust the position of the modified scale so the maximum value of 250 aligns with the needle.

Place the pendulum arm at position A on the rigid surface, so that it exactly touches the surface without vertical force. Lower the pendulum arm 10mm, measured at Position A in Figure 12. To enable measurements with the same setting each time, either mark the position of the holder in relationship to the test foot and designate it as position B (See Figure 13) or use a 10 mm spacer for each measurement.



**Figure 13- Position B marker**

Place the pendulum with test foot on a force platform or in a tensile strength apparatus, capable of measuring to an accuracy of 0.5N , and measure the force over the first 10 mm of compression. The test foot pressure shall be in the range of  $32\text{N} \pm 2\text{N}$  over the first 10 mm.

### 14.3.2 Measurement

Place the apparatus on the test specimen. Use the levelling screws to set the apparatus horizontal. Hold the arm pendulum so that the Position A on the test foot and the Position A on the frame of the apparatus are opposite each other. Use the vertical adjustment screw to decrease the height of the pendulum with 10 mm until the shoe profile is pressed into the surface.

Lift the test foot from the surface and raise the pendulum arm until it makes contact with the support mechanism. Place the needle opposite the value of 250 on the scale. Release the pendulum arm.

Record the value on the scale corresponding to the maximum movement of needle during the test. This is the Sliding Value (SSV).

Record the maximum deceleration that occurred during the test and designate it the Deceleration Value (SDV).

Repeat the measurement seven times ensuring the apparatus is moved each time so no area is tested twice and no test is made within 100mm of the sides of the test specimen.

### 14.4 **Calculation and expression of results**

Disregard the highest and lowest recorded values of SSV and SDV and calculate the mean of the remaining five values.

Report the mean value of SSV as a dimensionless value e.g. 100.

Report the mean value of SDV in gravities to one decimal place e.g. 3.5g.

Note: Values of uncertainty for this test are yet to be established.

### 14.5 **Laboratory tests at 23 +/- 2° C**

Determine the SSV and the SDV under dry and wet conditions, as appropriate.

### 14.6 **Field tests**

#### 14.6.1 Test Conditions

Tests shall be made under the meteorological conditions found at the time of test subject to the limits of Section 5.3. The conditions shall be reported.

#### 14.6.2 Procedure

Determine the SSV and the SDV at each test location.



## 15 Determination of Skin / Surface Friction and Skin Abrasion (FIFA Test Method 08)

### 15 Determination of Skin / Surface Friction (FIFA Test Method 08)

#### 15.1 Principle

A rotating test foot on which a silicon skin is mounted is allowed to move across a test specimen in a circular motion and the coefficient of friction between the silicon skin and the test specimen calculated.

#### 15.2 Apparatus

The test apparatus comprises:

- Securisport ® Sports Surface Tester.
- Test foot as detailed in Figure 14
- Silicon Skin L7350 supplied by Maag Technic AG, Sonnentalsstrasse 8600 DUEBENDORF, Switzerland (Tel. +41 44 824 9191). When tested in accordance with the method for Skin Abrasion (Section 16 of this manual) the average force recorded on the new skin shall be  $5 \pm 0.3\text{N}$ .
- Water level
- Polished steel test plate ( $0.2\mu\text{m} < \text{Ra} < 0.4\mu\text{m}$ ).

#### 15.3 Procedure

Caution: do not touch the silicon skin during the test.

##### Determination of sliding distance force – new test skins

Wash in water three silicon skin specimens each measuring 15cm by 8cm. Allow to air dry for 24 hours.

Attach a test skin to the test foot (glossy side exposed) using double sided adhesive tape and the clamping screws. Ensure the smooth surface of the silicon skin is the test face; the grooved side being attached to the test foot.



Test foot with clamping screws

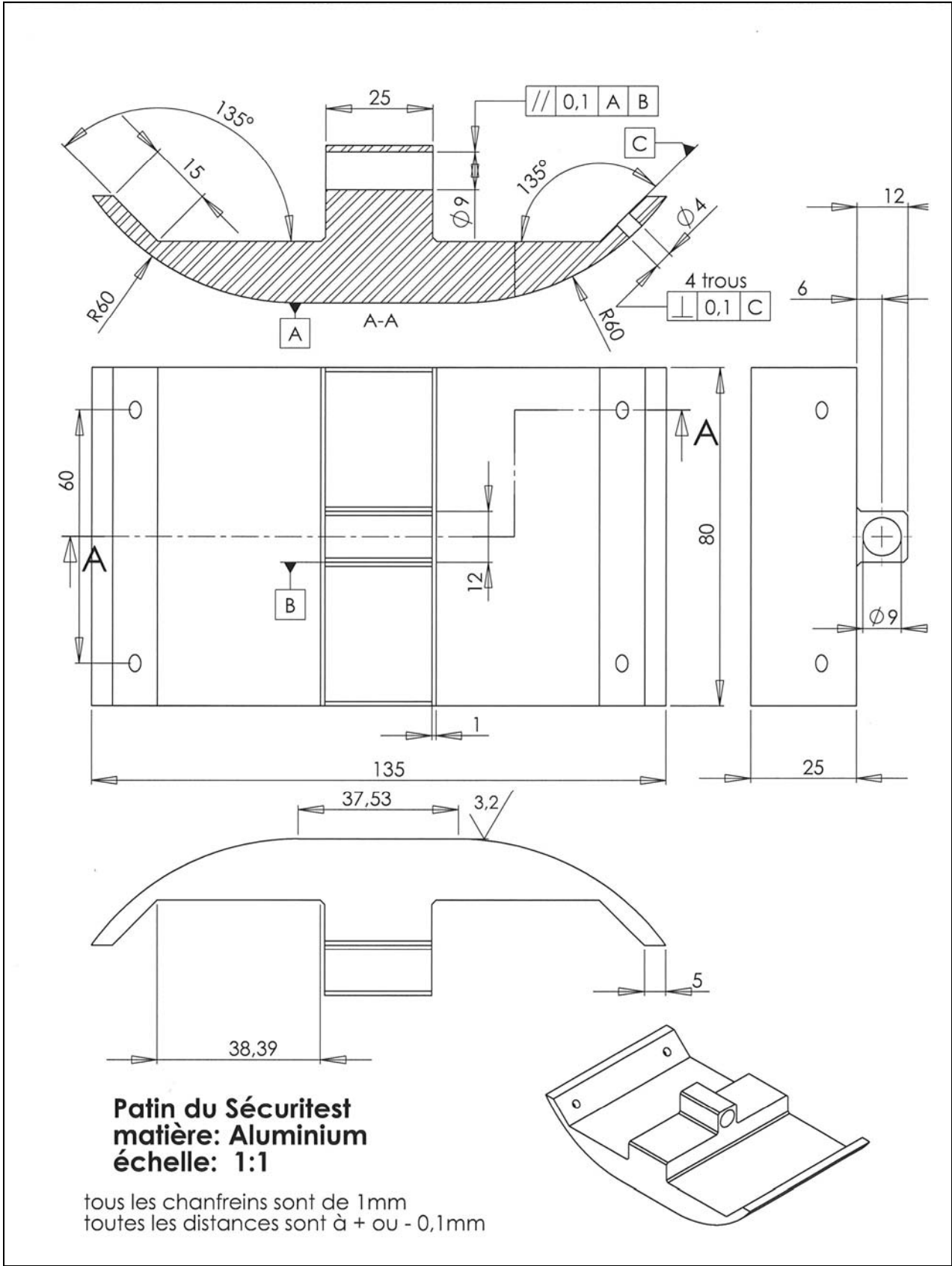


Figure 14 - Test Foot

Clean the metal test plate with acetone and allow it to evaporate for at least 5 minutes.

Attach the draw strings to the mounting screws on the test foot and place the test foot (with silicon skin) onto the clean test plate and add additional mass to obtain a total mass of  $1,700 \pm 50\text{g}$ , ensuring the test foot remains stable on the test plate.

Measure the force required to pull the silicon skin along the metal plate over a sliding distance of 100mm at a speed of  $500 \pm 10\text{mm/min}$ . Repeat the force measurement at least ten times.

Determine the average force over a sliding distance of 40mm and 80mm.

Calculate the average force ( $F_{\text{new skin}}$ ) of the ten measurements. Ensure the standard deviation is less than 0.3 and the average force is  $6 \pm 1.5\text{N}$ .

Repeat on two further samples of silicon skin.

Undertake the test under laboratory conditions of  $23 \pm 2 \text{ }^\circ\text{C}$ .



Determination of sliding distance force  
(note additional mass added to test foot)

#### Determination of skin friction

Undertake the test under laboratory conditions of  $23 \pm 2 \text{ }^\circ\text{C}$ .

Attach the test specimen to the laboratory floor to prevent movement during the test.

Attach the silicon skin to the test foot of the Securisport Sports Surface Tester using double sided adhesive tape and mount onto the apparatus. Adjust the test foot so it is positioned just above the test specimen.

Position the Securisport Sports Surface Tester over test specimen and adjust to level. Apply a vertical force to the test foot of  $100\text{N} \pm 10 \text{ N}$  and start the rotation of the test foot. Allow the test foot to make five complete revolutions at a speed of  $40 \pm 1 \text{ rev/min}$ ; sampling at a frequency of 40 Hz.

Ignoring any peak value occurring as the test foot starts to rotate calculate the mean coefficient of friction value as displayed on the Securisport.

Repeat the test three times, changing the synthetic skin and replacing any infill between tests.

Calculate and report the mean Coefficient of Friction of the three tests

#### Determination of skin abrasion

Carefully remove the test foot from the Securisport without touching the test skin. Remove any detritus from the test skin using compressed air.

Place the test foot (with silicon skin) onto the clean metal plate and add an additional mass to obtain a total mass of  $1,700 \pm 50\text{g}$ .

Measure the force required to pull the silicon skin along the metal plate over a sliding distance of 100mm at a speed of  $500 \pm 10\text{mm/min}$ . Repeat the force measurement at least ten times.

Determine the average force over a sliding distance of 40mm and 80mm.

Calculate the skin abrasion using the following formula:

$$\text{Skin abrasion} = 100 \times [F_{\text{new skin}} - F_{\text{abraded skin}}] / F_{\text{new skin}}$$

where:

$F_{\text{(new skin)}}$  = the mean average force of the second to fourth tests prior to the Skin Friction test

$F_{\text{(abraded skin)}}$  = the mean average force of the second to fourth tests after the Skin Friction test

Report the result to the nearest 1% e.g. 10%

Repeat the test three times.

Note: Values of uncertainty for this test have are yet to be established.

## **16 Procedure for simulated mechanical abrasion during use (FIFA Test Method 9)**

### **16.1 Principle**

Two studded rollers are traversed over a test specimen of artificial turf for to simulate the mechanical abrasion of the surface that occurs during normal use.

### **16.2 Test apparatus**

Lisport Wear Machine having a stud configuration as shown in Figure 1 (Section 3). The number of studs per cylinder shall be  $145 \pm 5$ . The linear speed of movement (to and fro) of the roller carriage shall be  $0.25 \pm 0.05$  ms<sup>-1</sup> and the transversal movement of the sample tray shall be  $20 \text{ mm} \pm 1 \text{ mm}$ , at a speed of  $0.015 \pm 0.005$  ms<sup>-1</sup>. The studded rollers shall be geared so the speed of rotation of one roller is  $40 \pm 2\%$  faster than the other. The design of the machine shall ensure the studs do not repeatedly impact the same spots. This may be achieved by free movement of the cylinders at the end of each a cycle.

Note: the test report should detail whether transversal movement was used or not.

### **16.3 Test specimen**

Test specimen of artificial turf measuring 800mm by 400mm of which at least 500mm by 300mm shall be uniformly abraded.

### **16.4 Procedure**

Mount the test specimen into the sample tray and fill (if applicable) strictly in accordance with the manufacturer's instructions.

Place the prepared test specimen in the Lisport Wear Machine and adjust the rollers' height to ensure full stud contact with the infill layer or carpet pile as appropriate.

Undertake 1,000 cycles (one cycle comprises one complete to and fro movement). Stop the test and replace any fill material that has been dislodged from the test specimen and is lying in the sample tray, do not add new material to the test specimen. Lightly brush the pile to lift.

Repeat the procedure stopping the machine after 2000, 3000, 4000 and 5000 cycles and replace any fill material that has been dislodged from the test specimen and is lying in the sample tray, do not add new material to the test specimen. Lightly brush the pile to lift.

Carry out a further 200 cycles (5,200 in total) before removing the sample tray containing the test specimen from the Lisport. Do not reapply any fill material that has been dislodged.

Carefully remove the test specimen from the sample tray ensuring the test specimen and fill is not disturbed. Do not brush or lift the pile of the carpet.

Photograph the test specimen to show the general effects of the simulated wear.

Assess the fully conditioned area (not the ends) of the test specimen as required for the specified properties.

## **17 Procedure for Artificial Weathering (FIFA Test Method 10)**

### **17.1 Principle**

Test pieces of pile yarn and polymeric infill are exposed to artificial weathering by fluorescent UV lamps under controlled environmental conditions and the resulting changes in colour, appearance and selected physical properties are determined.

### **17.2 Apparatus**

Artificial weathering cabinet using fluorescent UV lamps and environmental control having the following features:

- UV - A 340 nm lamps in accordance to ISO 4892 - Part 3.
- Exposure chamber constructed from inert material to provide uniform radiance with a means for controlling the temperature.
- Provision for the formation of condensation or spraying of water onto the exposed face of the specimen.

In apparatus designed to wet the exposed faces of the specimens by means of a humidity-condensing mechanism, the water vapour shall be generated by heating water in a container located beneath and extending across the whole area occupied by the specimens. The specimen racks (completely filled with specimens) shall constitute the sidewall of the exposure chamber, so that the backs of the specimens are exposed to the cooling effect of the ambient room air.

If condensation is provided by spraying of the specimens the condensing water shall conform to sub-clause 4.6 of ISO 4892 - Part 2

- Means of mounting specimens so that the exposed face is located in the plane of uniform radiance and is not within 160 mm of the ends of the lamps or within 50 mm of the edge of a flat lamp array.

Note: Lamp replacement, lamp rotation and specimen rearrangement may be required to obtain uniform exposure of all specimens to UV radiation and temperature. The manufacturer's recommendations for lamp replacement and rotation shall be followed.

- A black-standard thermometer conforming to sub-clause 5.1.5 of ISO 4892 Part 1
- Specimen holders made from inert materials that will not affect the results of the exposure.

### **17.3 Exposure conditions**

The exposure cycle shall comprise  $240 \pm 4$  min of dry UV exposure at a black-standard temperature of  $55^{\circ}\text{C} \pm 3^{\circ}\text{C}$ , followed by  $120 \pm 2$  min of condensation exposure, commencing once equilibrium has been attained, without radiation, at a black-standard temperature of  $45^{\circ}\text{C} \pm 3^{\circ}\text{C}$ .

## 17.4 Procedure

Mount test specimen of pile yarn in the exposure racks with the test surface facing the lamps. Fill any spaces, using blank panels to ensure uniform exposure conditions.

Mount tests specimens of infill materials in sample trays placed in the cabinet with the test surface facing the lamps.

Expose the test piece, measuring the irradiance and radiant exposure at the surface of the test piece. After an exposure of  $(4896 \pm 125)$  MJ/m<sup>2</sup>, carefully remove the test piece from the exposure cabinet.

NOTE An exposure of  $(4896 \pm 125)$  MJ/m<sup>2</sup> will take approximately 3 000 h.

Carefully remove the test specimen from the sample tray

## 17.5 Assessment of test specimens

### 17.5.1 Pile yarn(s)

Assess the change in colour of the exposed test specimen when compared to an unexposed test specimen using the grey scale in accordance with EN ISO 20105-A02.

Determine the tensile strength of exposed specimens of the pile yarn(s) in accordance with EN 13864 (minimum gauge length 100mm) and calculate the percentage change in tensile strength compared to test specimens of unexposed yarn.

### 17.5.2 Polymeric infill materials (rubbers, thermoplastics, etc)

Assess the change in colour of the exposed test specimen when compared to an unexposed test specimen using the grey scale in accordance with EN ISO 20105-A02.

Photograph specimens of exposed and unexposed polymeric infills to show any visual effects of the artificial weathering.

## 19 List of International and European Standard test methods adopted by FIFA

In addition to the test methods described in this manual FIFA has adopted the following International and European Standards for measuring the material properties of football turf.

Particle size of unbound sub-bases	EN 933 -1: 1997	Determination of particle size; sieving method
Particle size of infill materials	EN 933 – 1: 1997	Determination of particle size; sieving method -see below
Bulk density of infill materials	EN 1097 – 3: 1998	Tests for mechanical and physical properties of aggregates - Part 3: Determination of loose bulk density and voids
Thickness of shockpads and depth of infill layers	EN 1969: 2000	Surfaces for sports areas: Determination of thickness of synthetic sports surfaces
Joint strength of artificial turf	EN 12228: 2002	Surfaces for sports areas - Determination of joint strength of synthetic surfaces
Tensile strength of shockpads	EN 12230:2003	Surfaces for sports areas: Determination of tensile properties of synthetic sports surfaces
Water permeability of artificial turf surfaces	EN 12616: 2002	Surfaces for sports areas: Determination of water infiltration rate – laboratory test using single ring infiltometer
Surface Regularity	EN 13036 -7: 2003	Irregularity measurement of pavement courses - The straightedge test
Immersion in hot water	EN 13744: 2004	Surfaces for sports areas: Procedure for accelerated ageing by immersion in hot water
Shock absorption of shockpads	EN 14808: 2005	Surfaces for sports areas Determination of Shock Absorption
Mass per unit area of artificial turf	ISO 8543: 1998	Textile floor coverings: Methods for determination of mass
Tufts per unit area of artificial turfs	ISO 1763: 1986	Carpets: Determination of number of tufts and or loops per unit length and per unit area
Pile length above backing of artificial turf	ISO 2549: 1972	Hand knotted carpets: Determination of tuft leg length above woven ground
Mass per unit area of artificial turf and pile weight	ISO 8543: 1998	Textile floor coverings: Methods for determination of mass
Tuft withdrawal force	ISO 4919: 1978	Carpets: Determination of tuft withdrawal force
Particle shape of infill materials and unbound base materials	prEN 14955: 2004	Surfaces for sports areas: Determination of composition and particle shape of unbound mineral surfaces for outdoor sports areas



The particle size of infill materials shall be determined in accordance with EN 933-1 ensuring a minimum of four sieves with mesh sizes within the test specimens overall grading range are used. The sieves shall be selected from the following sizes as appropriate:

200µm, 315µm, 400µm, 500µm, 630µm, 800µm, 1.00mm, 1.25mm, 1.60mm, 2.00mm, 2.50mm, 3.15mm, 3.35mm, 4.00mm